



**ZERO GRAVITY
FILTERS
Brighton, MI**

**EASycLEAN SIMPLEX AUTOMATIC
External Backwash**

Operating and Maintenance Manual

EasyClean Simplex Automatic External Backwash

TABLE OF CONTENTS

<u>Section Number</u>	<u>Description</u>	<u>Page Number</u>
	Standard and Limited Warranty	3
	Packing List	4
	Installation Guide	5
	Operating Manual	9
1.0	Components	10
1.1	Filter Pods	10
1.2	Three-way Valves	10
1.3	Filter Element	10
1.4	Control Panel	10
2.0	Operating Guidelines	11
2.1	Filter Operation	11
2.2	Differential Pressure Switch	11
2.3	Backwash Duration Timer	12
2.4	Backwash Interval Timer	12
2.5	Control System	13
2.5.1	Program Adjustments	14
2.5.2	Fault Conditions	15
3.0	Filter Start-Up	17
4.0	Recommended Maintenance	18
4.1	Removal, Inspection and Cleaning of Filter Elements	18
4.2	Replacement of Filter Elements	19
5.0	Filter Diagnostics	20
5.1	Fault Indication	20
5.2	Fault Finding	21
6.0	Spare Parts	22
Exhibit 1	Pressure/Flow Diagram	
Exhibit 2	Generic Wiring Diagram (#ZG10123)	
Exhibit 3	External Panel Fittings (#ZG10047)	

Version 3.0
Reference: EasyClean 3.0
August 2005

Standard and Limited Warranty

Seller warrants that title to goods sold hereunder is unencumbered at time of sale. All other warranties are expressly disclaimed including, but not limited to, merchantability, fitness for purpose, and all other warranties, express or implied. Seller expressly disclaims any liability for damages, actual, consequential, incidental or otherwise, for injury to property of buyer, its agent or third persons in custody of goods sold hereunder. Seller may determine to repair or replace any defects in goods of its own manufacture, which arise from defective materials or workmanship during the twelve (12) months, or (60) months on the filter elements, following the date of tender of delivery to the end purchaser if buyer gives seller timely written notice with a description of the basis for claim. Seller may refund amounts paid by buyer without other liability to buyer. The buyer acknowledges and agrees that the limitations of warranty, liability and remedy are fair and not unconscionable and the sole and exclusive remedies afforded at law with all other statutory and common law remedies being hereby waived. A claim under the warranty by the buyer for repair or replacement of goods shall be timely filed with the seller in accordance with the written procedures of the seller in effect at the time of any such claim.

EasyClean Simplex Automatic External Backwash

PACKING LIST

Contents:

1. (1) Filter pod with a differential pressure switch connected hydraulically to the pod.
Fitted to the pod are (2) pneumatically operated three-way valves.
2. (1) Control panel
3. (1) Filter element, (1) O ring, and (3) stainless steel screws
4. Operating manual & installation guide

Please read the accompanying “**Installation Guide**” provided before installing filter to system.

EasyClean Simplex Automatic External Backwash

INSTALLATION GUIDE

POWER SUPPLY

The filter requires 110 VAC, single-phase supply at 5 Amps. A cable gland is provided on the base of the control panel for the incoming power supply. The connecting terminals are located in the bottom left hand corner of the control panel. Power is connected directly to the 2 Amp miniature circuit breaker (MCB), connections for neutral and ground are located adjacent to the MCB (see drawing #ZG10123).

CONTROL PANEL

The control panel should be mounted as close to the filter assembly as possible while leaving sufficient room for easy access to the controls and opening of the panel door. The control panel should be mounted in a dry location.

PNEUMATIC CONNECTIONS

An 80 psi, clean and dry compressed air supply should be made to the ¼” bulkhead connector (labeled 5) and a ¼” bulkhead connection (labeled 6) is provided for exhaust.

Run 5/32” pneumatic airlines from the control panel bulkhead fittings to the filter. Connect in accordance with the following:

<u>Bulkhead fitting on Control Panel</u>	<u>Connection on Filter</u>
1	Inlet/Backwash Actuator
2	Inlet/Backwash Actuator
3	Outlet/Backwash Supply Actuator
4	Outlet/Backwash Supply Actuator
5	Air Supply to Control Panel
6	Exhaust from Control Panel

DIFFERENTIAL PRESSURE (DP) SWITCH

The filter is supplied with a DP switch connected hydraulically to the filter, the operating range of this switch is from 2 to 45 psi (differential pressure). Should the differential pressure across the filter exceed 45 psi, damage may occur to the switch.

A cable gland is provided on the base of the control panel for the electrical connections between the DP switch and the control panel. If a single micro-switch is used, connections are between normally closed (NC) and common (C) on the DP switch and terminals 1 and 2 in the control panel. If a second set of contacts are supplied for monitoring and

indicating a high differential pressure across the filter (**dual dial indicator**), then connect the second set of normally closed (NC) and common (C) contacts on the DP switch and terminals 3 and 4 in the control panel (see drawing ZG10123).

NOTE: On the dual indicator DP switch, the left set of terminals is related to the lower dial (backwash set point) and the right set of terminals is for the upper dial (high set point indication).

PIPE CONNECTIONS

The filter's inlet, outlet, backwash supply, and backwash connections are 1" NPT female. The backwash line should be plumbed to a suitable drain or tank capable of handling the system's pressure. **To avoid excessive pressure drops, which could impair backwash effectiveness, do not run the backwash line more than 10 feet with the ID of the line no less than 3/4".**

FILTER SUPPORT

The filter can be supported by the pod.

DIMENSIONS AND WEIGHT

Weight: Dry = 30 lbs excluding the element and 32 lbs with the element
 Wet = 35 lbs (assuming water)

OPERATING REQUIREMENTS

The EasyClean Simplex filter requires a minimum system pressure of 20 psi and a minimum backwash supply source pressure of 25 psi if direct to drain. Please consult Zero Gravity Filters.

PUMP

Please contact Zero Gravity Filters for assistance in pump selection or for determining suitable backwash supply sources.

REGULATING VALVE

A regulating valve must be fitted on the discharge of the filter, enabling the user to balance the filter's pressure and flow rate.

ISOLATING VALVES

It is recommended that inlet and discharge isolating valves be fitted to the filter for ease of maintenance.

PRESSURE GAUGES

Pressure gauges must be fitted to the system to monitor both the inlet and discharge pressure of the filter. Gauges may be fitted between the pump and filter inlet and between the filter discharge and regulating valve.

INLET STRAINER

A coarse strainer must be fitted to the inlet side of the filter if particulates are greater than ¼" in size.

FILTER ELEMENT INSTALLATION

Once the filter has been installed per the Installation Guide and pressure tested, the filter elements can now be fitted by following the instructions below.

1. Undo the three ring nuts holding down the lid on the filter pod.
2. Remove the element holder from the filter pod.
3. Provided with the filter are an 'O' ring, and three (3) stainless steel countersunk screws.
4. Remove the filter element from its packaging tube.
5. Place the small 'O' ring into the groove on top of the filter element, see drawing below.
6. Using the screws provided, secure the filter element to the element holder as shown below.
7. Lightly grease the outer 'O' ring on the element holder and insert the filter element into the filter pod, ensuring that the element holder is fully seated onto the shoulder of the filter pod.
8. Replace lid to top of filter pod and hand tighten each ring nut.
9. Finally, tighten down each ring nut a further half-turn.

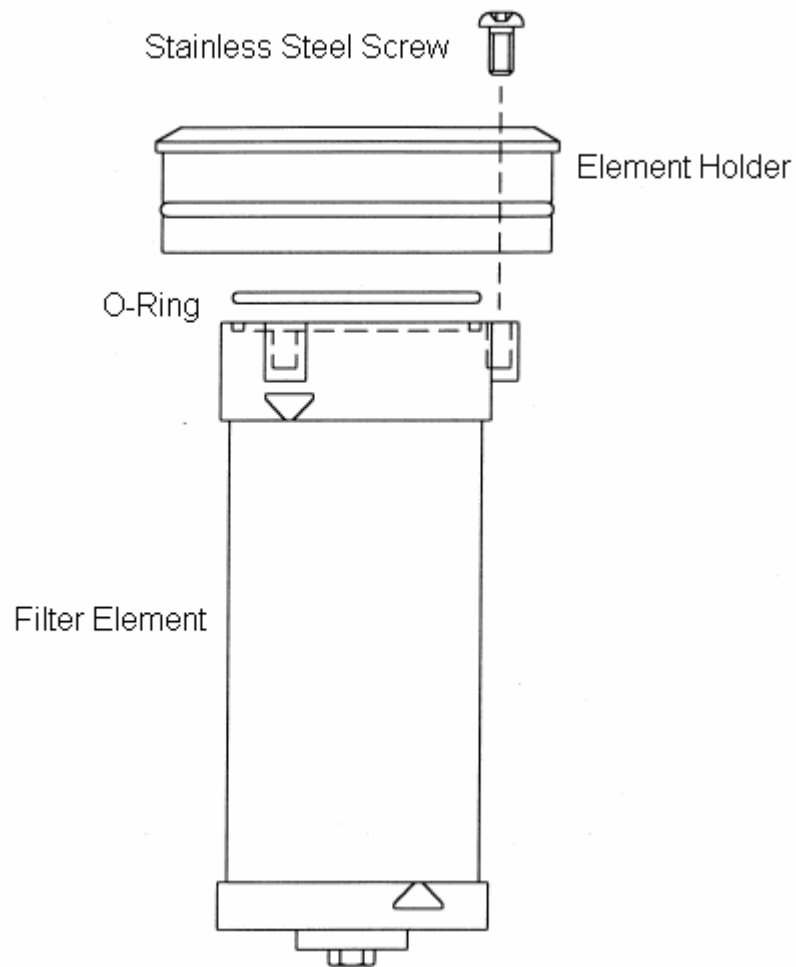

CAUTION: WHEN FITTING ELEMENTS TO THE ELEMENT HOLDERS, THE ELEMENTS MUST BE HELD BY THE VERY TOP PORTION OF THE ELEMENT'S PLASTIC CAGE, ELSE DAMAGE MAY RESULT TO THE ELEMENT OR CAGE ASSEMBLY. ONCE FITTED, THE SCREWS MUST BE CHECKED FOR TIGHTNESS ONE HOUR AFTER OPERATION.

EasyClean Simplex Automatic External Backwash

OPERATING MANUAL

Description

The EasyClean Simplex Automatic comprises a single filter element housed in a filter pod. The backwash sequence is controlled by a PLC contained in a wall mounted enclosure. The operation of the backwash sequence is accomplished by operating a system of pneumatically operated valves. A differential pressure switch is fitted on the side of the pod and connected hydraulically to that pod.

Operating Parameters

Power Supply:	110 VAC, 5 Amp supply
Controls Supply:	24 VDC
Minimum Operating Pressure:	20 psi system pressure, 25 psi backwash supply pressure
Maximum Operating Pressure:	80 psi (higher pressures are available)
Maximum Differential Pressure:	40 psi
Static Test Pressure:	230 psi
Maximum Operating Temperature:	135° F (higher temperature ratings available)
Flow Rate:	see flow chart (Exhibit 1)
Micron Ratings:	12, 25, 50, 75, 125, 200 and 400 micron.
Minimum Air Pressure:	80 psi
Maximum Air Pressure:	100 psi

Materials Composition

Filter Material

Filter Pod:	Carbon steel, stainless steel 304, or stainless steel 316
Filter Element:	Stainless steel 304L, DTD 734 with glass filled polypropylene cage, stainless steel cage recommended for higher pressure and temperature applications.
Element Holder:	Glass filled polypropylene (stainless steel available), stainless steel screws.
3-Way Valves:	1" 3-way valve, 'T' ported, bronze body, stainless steel 316 ball, and PTFE seats. Stainless steel 316 body is available.
Pneumatic Actuator:	Double acting, developing 156 Lb Ins at 80 psi. Manufactured by Flow-Tek, model DA050.
DP Switch:	One micro switch, brass wetted parts, fitted with visual setting indicator and Nitrile seals. Two micro switches and stainless steel wetted parts with Viton seals available.
'O' Rings:	Buna standard, Viton and EPDM available.

1. COMPONENTS

1.1 FILTER POD

Manufactured from either carbon steel or stainless steel, the filter consists of a single filter pod containing a filter element.

1.2 THREE-WAY VALVES

Fitted to the inlet and outlet of the filter pod are two pneumatically operated 3-way, 'T' ported valves. During backwash, the valves are operated simultaneously to backwash the filter element by shutting off the filter's inlet and outlet ports while opening the backwash and backwash supply ports, see Section 2.1 for a more detailed explanation.

1.3 FILTER ELEMENT

The filter element is manufactured from stainless steel 304 and is made to different micron specifications. Element selection is dependent on the nature of the contaminant in the fluid to be filtered. As can be seen from the flowchart in Exhibit 1, the smaller the micron size the lower the flow rate through the filter. Correspondingly, this will also directly affect the clean differential pressure across the filter.

1.4 CONTROL PANEL

The filter's controls are contained in a separate wall mounted enclosure. The principal components of the control system are a Siemens PLC and 24 VDC transformer, Norgren air solenoid valves, terminals, Allen-Bradley lamps and buttons, and a backwash counter. Connections between the panel and filter include pneumatic air lines and a 24 VDC electrical connection for the DP switch.

Fitted with the control panel are the following:

1. The Power Lamp (green) indicates that the 24VDC supply is connected to the PLC.
2. The Backwash Lamp (yellow) indicates that a backwash cycle is in progress.
3. The Fault Lamp (red) indicates an error has occurred, see Sections 2.5.2 and 5.0.
4. The Backwash Button initiates a manual backwash.
5. The MCB (miniature circuit breaker) is provided to allow the power supply to the PLC to be switched off and on easily and to break at any load exceeding 2 Amps. **Ensure that power is disconnected elsewhere before working on the panel.** The MCB is located in the bottom of the control panel (refer to drawing ZG10123).
6. The Backwash Counter counts the total number of backwash cycles and is not resettable.

2.0 OPERATION GUIDELINES

Before operating the filter, ensure that it has been installed per the INSTALLATION GUIDE provided. Failure to do so could affect the filter's performance and void the filter's warranty.

2.1 FILTER OPERATION

The DP switch monitors the difference in pressure between the pod's inlet and outlet, and upon reaching a user determined DP set-point, an electrical signal will be sent from the DP switch to the control panel.

The operation of the valves during backwash is controlled by the PLC, which controls the opening and closing of each valve and for how long the valves are left open. Adjustments to the backwash cycle are made by altering the PLC's program. The control panel initiates the backwash sequence as follows:

1. The 3-way valve fitted on the filter's inlet is operated, which shuts off the inlet port while simultaneously opening the backwash port.
2. After approximately a one second delay, the 3-way valve fitted on the filter's outlet is operated to shut off the filter's discharge while simultaneously opening the backwash supply port.
3. This will allow the backwash supply fluid to enter the pod while flowing in a reverse direction from the inside to the outside of the filter element, causing the filter element to open along its length while 'shimmering'. The combination of the filter element opening and 'shimmering' allows for a very quick and efficient backwash.
4. The backwash with the contaminated fluid is discharged through the bottom of the pod.
5. This backwash process takes approximately 2-3 seconds. Upon completion of the backwash, the outlet valve will operate to open the filter's discharge and then within a second, the second 3-way valve will operate to open the filter's inlet.

During backwash, all debris is removed from the outside of the filter element, even debris that may be lodged on the surface of the filter element. This results in a very efficient backwash with little fluid required. Once the backwash has been completed, the filter will return to its clean differential pressure each and every time.

2.2 DIFFERENTIAL PRESSURE (DP) SWITCH

The difference in pressure between the filter's inlet and discharge operates a diaphragm, which in turn will open the normally closed electrical contacts within the switch. This in turn provides a signal to the control system which then initiates a backwash.

The DP set point may be adjusted by turning the adjusting nut located inside the switch cover. Turning this nut will alter the setting on the indicator located on the outside of the switch. This indicator is for reference only. The actual differential pressure at which the switch operates is determined by calculating the difference between the inlet and outlet pressure gauges.

It is imperative that the clean DP of the filter is ascertained prior to setting the backwash set point on the switch. To set the DP set point, determine the maximum acceptable DP that the filter can impose on the overall system and set the switch accordingly. Note, the closer the backwash set point is to the filter's clean DP, the more frequent the filter will backwash. It is usually necessary to try a number of settings until the best compromise is reached. **Maximum setting for the DP switch is 40 psi.**

The DP switch is factory set at approximately 10 psi. **Note: The filter requires a minimum of 25 psi on the discharge side of the filter for an efficient backwash.**

2.3 BACKWASH DURATION TIMER

The backwash duration is the length of time that the 3-way valves will remain in the backwash position and how long the pod is backwashed. This is how adjustments are made to achieve optimum backwash efficiency. The backwash duration can be set as low as 1 second without hindering backwash efficiency. The longer the duration, the longer the filter remains off-line and the greater the backwash volume.

The objective when setting the backwash duration is to find the optimum balance between low backwash wastewater and full element cleaning. Full element cleaning is demonstrated when the filter returns to a clean DP as evidenced by comparing the inlet and discharge gauge pressures.

To alter the backwash duration, see section 2.5.1.

2.4 BACKWASH INTERVAL TIMER

The EasyClean filter is recommended to be operated with the DP switch provided. This ensures that backwashing follows the contaminant load on the filter, which will often be variable. The EasyClean has an additional advanced facility which takes over from the DP switch at times of low contaminant loading. This feature is called the backwash interval timer and is factory set to ten hours. This ensures that the filter does not spend excessive amounts of time inactive during conditions of low contaminant loading. This facility avoids the problems frequently encountered with mechanical equipment which remains static for long periods of time.

To alter the interval time, see section 2.5.1.

Note: Adjustments to both timers must be done when in filtration mode and not during a backwash. Therefore, it is advisable to initiate a manual backwash immediately after any alterations are made to ensure that the new settings have been registered in the PLC.

2.5 CONTROL SYSTEM

EXPLANATION OF TERMS

PLC	Programmable Logic Controller. A Siemens LOGO! 24RCL is provided and is supplied from the 24VDC power supply within the panel. The power supply to the panel is an 110VAC supply. To determine the program version that is installed on the PLC, depress the reset button three seconds and view the PLC's display.
Input	24VDC signals fed into the PLC from switches, buttons etc. The 24RCL has the capacity for 12 inputs.
Output	Information in the form of 24VDC signals which can power indicator lamps, solenoid valves, counters, and factory DCS feedback (i.e. Honeywell System). The 24RCL has the capacity for 8 outputs.

I/O LIST

I ₁	Not Used
I ₂	Manual Backwash Button
I ₃	Differential Pressure switch contacts – Backwash set point
I ₄	Backwash Interval timer. (Allows the user to instigate a backwash after a preset time interval (set to 10 hours as default))
I ₅	High Differential Pressure switch contacts – High set point
I ₆	Not Used
I ₇	Not Used
I ₈	Not Used
I ₉	Not Used
I ₁₀	Not Used
I ₁₁	Not Used
I ₁₂	Reset Button
Q ₁	Inlet/Backwash Actuator
Q ₂	Outlet/Backwash Supply Actuator
Q ₃	Not Used
Q ₄	Not Used
Q ₅	Not Used
Q ₆	Not Used
Q ₇	Backwash Counter and Backwash Lamp (customer feedback) 24 VDC
Q ₈	Common Fault (customer feedback) 24 VDC

2.5.1 PROGRAM ADJUSTMENTS

The LOGO! program is simply a series of control statements contained within program segments or “Boxes”. Adjustments to timers within the program are made by gaining access to the appropriate box and changing the setting.

Most variables within the program are set at start up and should not be altered without reference to Zero Gravity Filters. Certain variables are adjustable at any time by the user and are outlined below.

Box No.	Customer Variable	Function	Default
B03	Yes	Backwash Duration. Sets time for which the 3-way valves remain open (and determines the amount of fluid used and length of backwash).	3.0 sec
B06	Yes	DP Debounce Time. Sets time for which DP switch contacts must remain open before backwash starts.	3.0 sec
B08	Yes	Backwash Interval Time. Sets interval between backwashes.	10.00 Hr
B34	Yes	Service Interval. Sets number of backwashes after which service interval is notified.	20,000
B46	Yes	High DP Debounce Time. Sets time for which High DP switch contacts must remain open before alarm indication.	10.0 sec

Adjustments are made by following the sequence described below:

- Step 1 Simultaneously press both blue keys (ESC + OK) on the front of the LOGO! Controller.
- Step 2 Select “Parameterize” option and press OK.
- Step 3 Use the up and down keys to arrive at the required box.
- Step 4 When the desired box has been located, press OK.
- Step 5 Use the left and right arrow keys to position the cursor over the required digit, and then use the up and down keys to change the value.
- Step 6 Once the correct value can be read, press OK. The up and down keys can be used to change another box if required. Finally, press ESC twice to return to the running program.

The time/date can be altered at step 2 above by selecting “Set Clock” and following similar steps as above.

Note:

T	=	actual time set
Ta	=	this facility allows the actual value of any particular timer to be observed while the program is running. This feature is useful in finding the optimum value for a setting.
Lim	=	the number value set
Cnt	=	the actual count reached

BACKWASH SEQUENCE

Once a backwash (self cleaning cycle) has been initiated by either the backwash button, DP switch, or interval timer the following sequence takes place:

1. The 3-way ball valve fitted on the inlet to the pod is operated, which shuts off the flow of fluid into that pod while simultaneously opening the backwash port.
2. After approximately a one second delay, the 3-way ball valve fitted on the outlet to the pod is operated, which shuts off the filter's discharge and opens the backwash supply port.
3. Because the backwash port is opened to atmospheric pressure, the backwash supply fluid, with a pressure greater than 25 psi, is allowed to flow from the inside to the outside of the filter element, backwashing the debris to drain.
4. The pod is then backwashed for the length of time set on the duration timer
5. Once the duration time expires, the 3-way valve fitted on the filter's discharge is operated to open the outlet port and then within a second, the second 3-way valve will operate to open the filter's inlet.

Note: If the backwash sequence is initiated by the DP switch, there is a three second debounce time (pause) between receiving the DP signal and starting the backwash. This debounce time eliminates unnecessary backwashes due to possible pressure surges in the system.

2.5.2 FAULT CONDITIONS

DP Switch Contacts Still Open. When the backwash is initiated by the differential pressure (DP) switch, the DP switch contacts will open to start the backwash. The contacts should close upon completion of the backwash cycle to indicate that the cleaning process is complete. If this is not the case and the DP contacts remain open for 20 seconds, the fault lamp will illuminate red and output Q8 will be energized. Also an error message will be displayed on the PLC stating:

**DP switch contacts
Still open
See manual**

To reset the fault lamp once the fault has been cleared, press the reset button on the front of the control panel. If the DP switch contacts have subsequently closed, then the fault lamp will turn off. If the fault lamp remains illuminated, then check for possible faults (see Section 5.1).

High DP Switch Contacts Open (Optional). A second set of contacts can be supplied to monitor the differential pressure across the filter and indicate an alarm condition if the DP exceeds the 'high' set point.

In normal operation, as the filter gets dirty the differential pressure across the filter will increase and will initiate a backwash at the user-defined set point. Upon initiation of the backwash, the differential pressure across the filter should decrease. However, if the differential pressure continues to increase, this may indicate a potential problem with the cleaning process.

The high DP set point is user-defined and if the DP across the filter reaches this set point for ten (10) consecutive seconds, then the contacts will open and the fault lamp will illuminate red (see Section 5.1). Also output Q8 will be energized and an error message will be displayed on the PLC stating:

**High DP contacts
open
See manual**

To reset the fault lamp once the fault has been cleared, press the reset button on the front of the control panel. If the DP switch contacts have subsequently closed, then the fault lamp will turn off. If the fault lamp remains illuminated, then check for possible faults (see Section 5.1).

Service Required. An internal counter totals all backwashes and gives a signal once a set point is reached. This counter is factory set at 20,000 cycles or backwashes. This is a useful facility to indicate that the filter should be serviced. When this set point is reached, the fault lamp will flash and the PLC display will read:

Service Required

Once flashing, please contact your local Representative or Zero Gravity Filters for spare part information (see Section 6.0). To clear this indication, press and hold the reset button for thirty seconds.

3.0 FILTER START-UP

Once the filter has been properly installed and after reviewing the filter's control system, the filter may be started by following the procedure below.

1. With inlet, discharge, and backwash valves closed, start any pumps serving the filter. Slowly open the inlet valve. Check and correct for any possible leaks.
2. Ensure that power is to the filter in accordance with the Installation Guide (the green LED should be illuminated). Ensure air to the control panel is at least 80 psi.
3. The discharge may now be slowly opened and the regulating valve adjusted to give the desired flow rate and pressure combination.
4. A final, on-line backwash check should be performed. Manually initiate a backwash by depressing the manual backwash button, check that the backwash counter advances, backwash LED illuminates yellow, and that the indicators on the pneumatic actuators move according to the backwash sequence outline in Section 2.5.1.

4.0 RECOMMENDED MAINTENANCE

Depending on the application, the filter element may require to be removed for cleaning at regular intervals. In any case, the following preventative maintenance program should be followed (see section 6.0 for spare parts listing):

Every Six Months

1. Visually inspect the following:
 - a. No leaking from the filter pod
 - b. No leaking from valves
 - c. Illumination of GREEN power lamp
2. Push manual backwash button and observe the following:
 - a. Illumination of YELLOW backwash lamp
 - b. Operation of each 3-way ball valve by observing rotation of indicator on each actuator.
 - c. Increase of backwash count.
3. Record backwash count

Every Twelve Months

1. Renew all O Rings
2. Visually inspect filter element

4.1 REMOVAL, INSPECTION AND CLEANING OF FILTER ELEMENT

To remove the filter element from the filter pod, perform the following procedure:

1. Take filter off-line, isolate, and drain.
2. Carry out the procedures outlined in the 'Installation Guide' for gaining access to the filter element ("Filter Element Installation").
3. Remove the filter element by gently lifting the element holder from the pod.

Once the filter element is removed, perform the following cleaning procedure:

1. If the contaminant is loose, then a simple shaking motion in water will suffice.
2. If light scale has formed, then any proprietary stainless steel cleaner will clean the elements to a like new condition. Always follow-up by running water down the center of the filter element to ensure that no debris is lodged between the turns of the coil.
3. If the filter element is heavily scaled, use a mild industrial acid and follow the product's safety precautions. Always follow-up by running water down the center of the filter element to ensure that no debris is lodged between the turns of the coil.

Once the filter element is cleaned, examine closely for any damage to the filter element and the support cage inside the element, finally check tightness of mounting screws. Refer to the 'Installation Guide' for instructions on replacing the filter element. Please refer to Section 6.0 for "O" ring part numbers.

4.2 REPLACEMENT OF FILTER ELEMENT

To replace the filter element, follow the procedure below:

1. Lightly lubricate the “O” ring on the element holder with an appropriate lubricant. Ensure that the “O” ring is fitted properly within the groove on the element holder.
2. Insert filter element into the pod.
3. Follow procedures outlined in the ‘Installation Guide’, entitled “Filter Element Installation”.
4. Restart any pump, open the valves to discharge, inlet, and backwash. Check filter performance.

5.0 FILTER DIAGNOSTICS

5.1 FAULT INDICATION

Listed below is a guide to the action required for the following faults indicated on the control panel.

INDICATION	REASON	ACTION
Fault lamp solid red and error message	DP switch contacts still open.	<p>Check operation of switch and pressure lines are clear.</p> <p>Check electrical connection between switch and panel.</p> <p>DP switch set point set to low.</p> <p>Check actual DP across the filter. If too high after a backwash, the filter element may need manual cleaning or backwash duration time extended (see sections 2.3 and 4.1)</p>
Fault lamp solid red and error message	High DP switch contacts still open.	<p>Check operation of switch and pressure lines are clear.</p> <p>Check electrical connection between switch and panel.</p> <p>High DP switch set point set to low.</p> <p>Check air supply is on and all pneumatic lines are intact.</p> <p>Check if flow rate or contaminate loading on filter has increased, if so, reduce flow rate, or consider coarser element</p>
Fault lamp flashes and message appears	Service interval has been reached.	Call supplier and arrange filter service and reorder supplies, see Section 6.0 for part numbers.

5.2 FAULT FINDING

Listed below is a guide to commonly asked questions regarding filter performance.

FAULT	POSSIBLE CAUSE	REMEDY
Excessive Backwash Frequency	Filter elements blocked or excessively fouled.	Clean and replace filter element, see Section 4.1 and 4.2.
	DP switch set too low.	Raise DP switch set point, see Section 2.2.
	Flow rate has increased.	Check and regulate.
	Contamination has increased.	Check, and if possible, increase DP switch set point. If contamination load cannot be corrected, a coarser element may be required, see Section 1.3 and 2.2.
	Backwash interval timer too low.	Reset, see Section 2.4.
Continuous Backwash	See Excessive Backwash Frequency faults and remedies.	
	DP switch has failed.	Verify by removing the DP switch's electrical cover and check that contacts are being switched on rise and fall of DP. Replace switch if necessary.
Upon completion of backwash, DP is higher than clean DP	Filter element blocked or excessively fouled.	Clean and replace filter element, see Section 4.1 and 4.2.
	System pressure too low for effective backwash.	Check and regulate.
	Backwash duration set too low to give thorough clean.	Increase backwash duration time setting, see Section 2.3.
	DP switch set point set too high causing excessive blinding of elements.	Check and regulate, see Section 2.2.
Fluid flows from backwash line after end of backwash cycle	Backwash valve is failing to close or seat properly	Check that the valve is being instructed to close. Look for Output Q1 or Q2 depending on which pod is leaking.
		Check air supply to actuator.
		If valve is still passing, dismantle and check for an object jamming the ball valve or damaged seats. Call supplier for service kit or replacement.
Filter Leaking	"O" seals failed, worn, or missing.	Check and replace as necessary. See Spare Parts List, Section 6, for part numbers.

6.0 Spare Parts

Recommended spare parts for the EasyClean Simplex Automatic are as follows. Please call either your local Representative or Zero Gravity Filters for pricing.

<u>Part Description</u>	<u>Part Number</u>
Filter Element – Stainless Steel 316 Cage Assembly	666***
Element Holder – Glass Filled Polypropylene	9003-001
Element Holder – Stainless Steel 304	9003-002
Element Holder – Stainless Steel 316	9003-003
Carbon Steel Housing (w/o filter element)	7610-001
Stainless Steel 304 Housing (w/o filter element)	7610-002
Stainless Steel 316 Housing (w/o filter element)	7610-003
Siemens LOGO PLC – 24 VDC, with Program	3000-001
EPROM with Program	3010-001
24 VDC Siemens 1.3 A Transformer	3002-001
Norgren Air Solenoid Valve	3100-001
DP Switch, visual indicator, 1 micro, brass	3200-001
DP Switch, visual indicator, 1 micro, stainless steel	3200-002
DP Switch, visual indicator, 2 micro, brass	3200-003
DP Switch, visual indicator, 2 micro, stainless steel	3200-004
1", 3-way 'T' ported valve and pneumatic actuator, brass	7510-001
1", 3-way 'T' ported valve and pneumatic actuator, st. st.	7510-002
1" Ball valve and pneumatic actuator, brass	7511-001
1" Ball valve and pneumatic actuator, stainless steel	7511-002
Eye Bolt Assembly (price per unit, 3 per pod)	7501-001
Complete Set of O rings – Buna (3 Total)	7500-001
Complete Set of O rings – EPDM (3 Total)	7500-002
Complete Set of O rings – Viton (3 Total)	7500-003

*** micron designation

Exhibit 1

EasyClean Pressure/Flow Curve

